

Interclamp®

The right connection



Technical Manual



Design & Materials

Interclamp is a versatile range of quality galvanised malleable iron pipe fittings with a multitude of uses. Designed for easy, simple and fast erection of rigid structures by hand with the minimum of tools, Interclamp is a cost effective, efficient system, particularly compared with traditional methods of construction such as welding, where specialist tools and extensive training and experience are required. Interclamps are made from malleable iron manufactured in conformance with BS EN 1562:1997, a dependable and well-proven material for this type of product. The fittings are then hot-dipped galvanised to BS EN ISO 1461:1999 to produce a durable corrosion resistant finished surface for extended life. For customising to specific end-user requirements, powder coating is available applied over the galvanising in a wide spectrum of RAL or BS colours on request. Quality setscrews are utilised, as these are a vital component in the high structural integrity of the fitting. To obtain optimum setscrew slip loads, the setscrew should be tightened to 40Nm, for which a ratchet wrench may be necessary.

Sizes

Five different size ranges of Interclamp are available as shown in the table, hence a suitable size can be selected for any particular application. Interclamps are easily identified by a type number of each design eg. 125 followed by a size code ed. D48, the latter part of which corresponds with the approximate outside diameter of the tube to be used (48.3mm = 1 1/2" nominal bore in this case). Hence a 90° elbow suitable for an 1 1/2" nominal bore tube in this example would be denoted as a 125-D48.

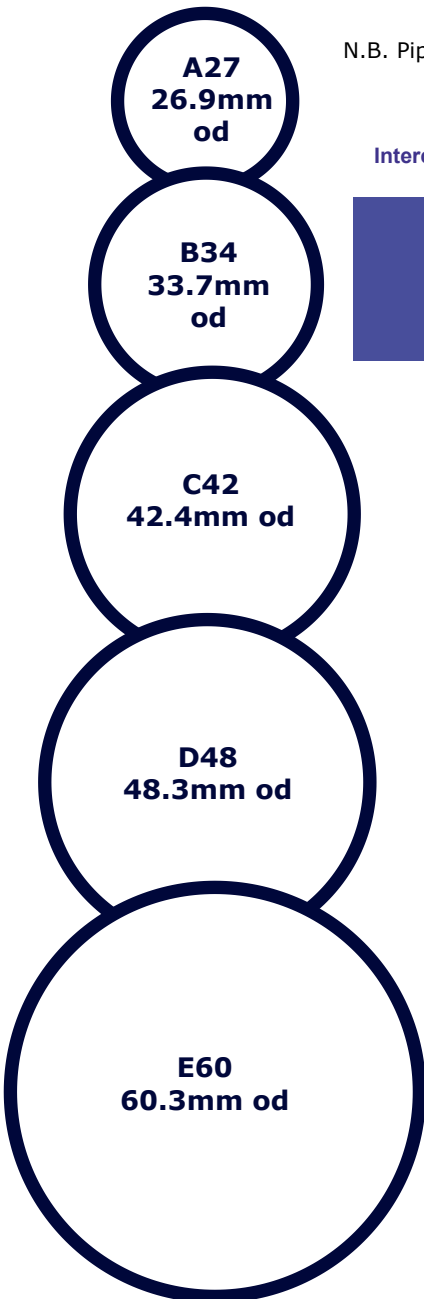

N.B. Pipe sizes not to scale

Interclamp Size	Nominal Bore	Outside Diameter
A27	3/4"	26.9mm
B34	1"	33.7mm
C42	1 1/4"	42.4mm
D48	1 1/2"	48.3mm
E60	2"	60.3mm

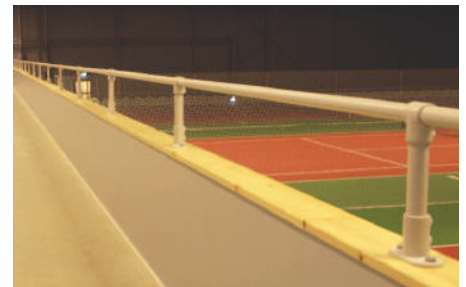

TÜV Rheinland Product Safety Type Approval

The following Interclamps have been tested and type approved by TÜV Rheinland, the leading independent test house in Europe: 101, 104, 116, 119, 125, 128, 129, 130, 131, 132, 135, 136, 137, 143, 144, 145, 146, 147, 148, 149, 150, 152, 153, 154, 155, 156, 158, 161, 165, 167, 168, 169, 173, 176, 185 & 191. The technical details in this publication were not part of the testing.



Health & Safety - COSHH

Interclamps are not considered hazardous within the meaning of COSHH Regulations 1988, provided that tube is cut using conventional pipe cutters or saws and the fittings are assembled in the normal way to the tube using hexagon keys or ratchets. The Interclamp system is designed to avoid the need for welding which does have both COSHH and other health and safety implications, especially if the materials are pre-painted, coated or galvanised in any way. We do not recommend that Interclamps are welded.



Applications

Although most commonly used in handrailing and safety guardrailing situations, the variety of structures made possible by the wide extent of the versatile range is only limited by your ingenuity. In addition, custom designed Interclamps are available on request. The following list gives an indication of typical applications:

- Handrails • Fences & Security Fencing • Playground Equipment • Milking Parlours
- Railway Guardrailing • Garment Racking • Market Stalls • Cycle Racks & Trolley Bays
- Sports Practice Nets (Golf, Cricket, Baseball, Soccer / Football etc • Sports Grounds & Arenas • Machinery Guards & Enclosures • Motorway Control Installations
- Road Signs • Roof Top Fall Prevention Systems • Heavy Duty Workstations • Safety Guardrails • Retail Displays & Shopfitting • Racking • Agricultural Enclosures • Greenhouses • Exhibition Stands & Displays • Industrial & Domestic Furniture • Temporary Buildings • Wheelchair Access Ramps • Theme Park Queue Management • Canopies & Car Ports • Lighting Supports • Roof Guardrails • Film Sets • Cable Reels • General Signage • Civic Amenity & Recycling Sites • Shipbuilding • Access Platforms & Mezzanine Floors • Water Treatment Works • Staircase Handrails • Commercial Billboard Frames • and many more.....

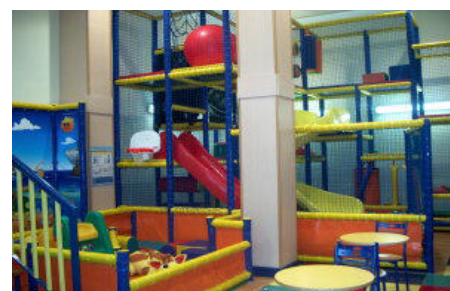

Design Loads

In the UK there are several British Standards which may apply to completed tubular structures. The most common horizontal design loads stated within the standards are as follows. The definitions of applicable areas are given as guidance only and have been derived from BS 6399-1:1996 Loading for Buildings Part 1: Code of Practice for Dead and Imposed Loads - please refer to the relevant British Standard for more precise information:

360 N/m (0.36 kN/m) - Single family domestic dwellings excluding external balconies and roof edges. Light pedestrian traffic routes in industrial and storage buildings excluding escape routes.

740 N/m (0.74 kN/m) - Other residential areas excluding areas where people may congregate. Areas not susceptible to over-crowding in office and institutional buildings and other areas in industrial and storage buildings. Stairs, landings, corridors, ramps, external balconies and roof edges in areas without obstacles and not susceptible to overcrowding. Footways within building curtilage adjacent to basements or sunken areas without obstacles and not susceptible to overcrowding.

1500 N/m (1.5 kN/m) - Areas where people may congregate including areas with tables and fixed seating. Examples are restaurants and bars and areas with fixed seating within 530mm of the barrier, balustrade or parapet. Footways or pavements less than 3m wide adjacent to sunken areas. Retail areas except areas subject to overcrowding. Vehicular access areas such as pedestrian areas in car parks.

Please note that for areas susceptible to over-crowding such as theatres, cinemas, discotheques, bars, auditoria, shopping malls, assembly areas, studio and footways or pavements greater than 3m wide adjacent to sunken areas, higher design loads are required. For grandstands and stadia, reference must be made to the relevant certifying authority to obtain relevant design load criteria.

Please contact us for further information on meeting design loads. In particular, it must be stressed that the correct choice of tube specification and upright separation is critical to meeting design loads.

Guidelines for Construction & Fixings

Please note that the ultimate responsibility for the correct choice of size and type of fitting for any application belongs with the customer. The customer is responsible for ensuring that the construction or structure is sufficiently strong to support the weight of its component parts plus any applied load, and that suitable fixings are used. We do not recommend that Interclamp fittings are welded and we strongly recommend that types 132 and 152 are always used where baseplates are required, fitted so that the fixing holes are in line with the applied load. To provide sufficient stability, whole structures must not be made from swivel fittings alone.

In order to determine the correct choice of fixing for any given application, please contact a reputable distributor or manufacturer of fixings. Please note that chemical anchors may need to be specified in order to meet 740N/m and 1500N/m design loads. The strength of any fixed tubular structure is dependent not only on the choice of fittings, tube and any fasteners used, but also the civil structure (eg. concrete slab, wall etc.) to which it is fixed.

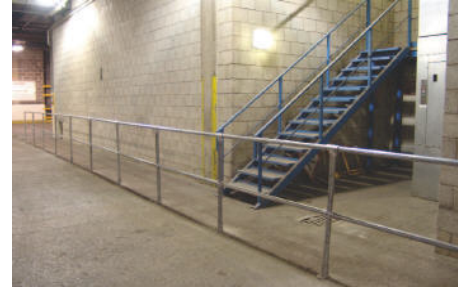
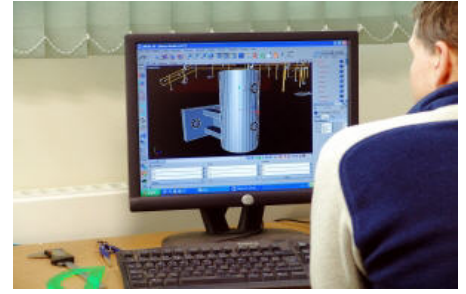

101 - Short Tee

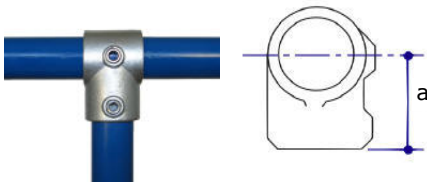

90° butt joint, often used to join intermediate uprights to top rails and middle rails to end uprights on level sites. This Interclamp cannot be used where through tube (horizontal in photo) has to be joined within the fitting (see 104).

	a mm	b mm	c mm	d mm	e mm	Dia mm	Wt kg
A27	41						0.19
B34	46						0.30
C42	60						0.46
D48	68						0.59
E60	84						0.96

101 - Reducing Tee

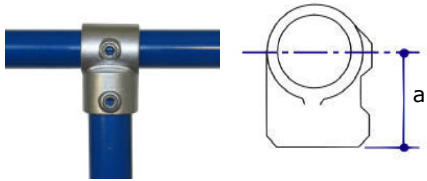

Used to join tubes of unequal size on level sites. This Interclamp cannot be used where through tube (horizontal in photo) has to be joined within the fitting.

	a mm	b mm	c mm	d mm	e mm	Dia mm	Wt kg
C42/B34	57						0.38
D48/C42	63						0.51
E60/D48	74						0.67
B34/C42	56						0.44
C42/D48	68						0.58

104 - Long Tee

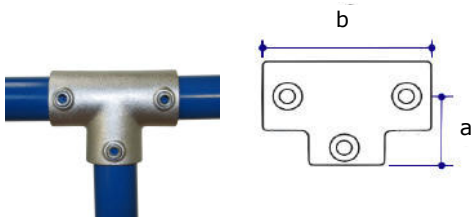

90° joint, often used to join intermediate uprights to top rails on level sites. This Interclamp can be used where through tube (horizontal in photo) has to be joined within the fitting. Where such a joint is not required, type 101 can often be used as an alternative.

	a mm	b mm	c mm	d mm	e mm	Dia mm	Wt kg
A27	41	82					0.36
B34	46	92					0.49
C42	60	120					0.85
D48	68	135					1.06
E60	84	168					1.65

116 - Corner (Middle Rail)

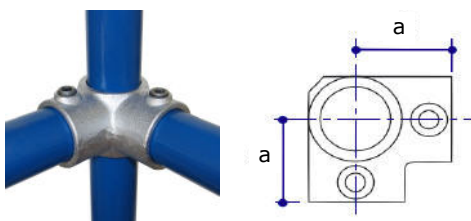

90° corner joint, often used on middle rail on level sites and often paired with type 128. The through tube (vertical in photo) cannot be joined within the fitting.

	a mm	b mm	c mm	d mm	e mm	Dia mm	Wt kg
A27	41						0.28
B34	48						0.41
C42	60						0.67
D48	68						0.84
E60	84						1.26

119 - Cross (Middle Rail)

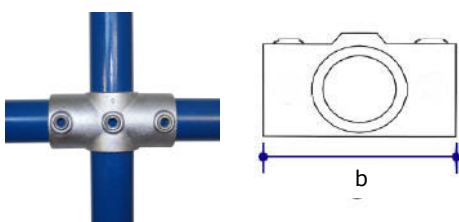

90° joint, often used between middle rail and uprights on level sites and often paired with type 101 or 104. The through tube (vertical in photo) cannot be joined within the fitting.

	a mm	b mm	c mm	d mm	e mm	Dia mm	Wt kg
A27		82					0.31
B34		92					0.40
C42		120					0.61
D48		135					0.81
E60		168					1.27

119 - Reducing Cross

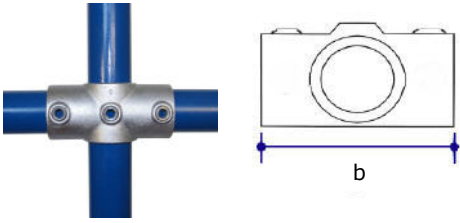

90° joint, often used between middle rail and uprights on level sites and often paired with type 101 or 104. The through tube (vertical in photo) cannot be joined within the fitting.

	a mm	b mm	c mm	d mm	e mm	Dia	Wt kg
C42/D48		122					0.65

123 - Variable Elbow 40° to 70°

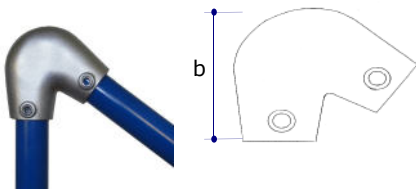

Variable 40° to 70° angle joint, often used to join staircase top rail to upright at top end of staircase.

	a mm	b mm	c mm	d mm	e mm	Dia	Wt kg
D48		134					1.34

124 - Variable Elbow 15° to 60°

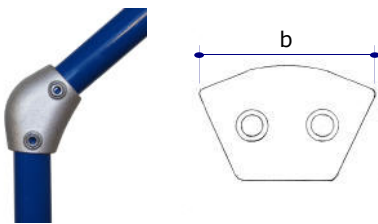

Variable 15° to 60° angle joint, often used to join staircase top rail to end uprights.

	a mm	b mm	c mm	d mm	e mm	Dia	Wt kg
B34		91					0.46
C42		110					0.61
D48		122					0.80

125 - Elbow

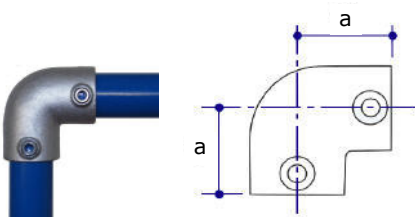

90° angle joint, often used where top rail meets end upright on level sites.

	a mm	b mm	c mm	d mm	e mm	Dia	Wt kg
A27	41						0.24
B34	46						0.36
C42	60						0.62
D48	68						0.78
E60	84						1.26

127 - Adjustable Long Tee

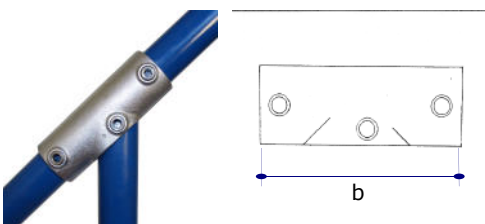

Adjustable from 30° to 45°, often used on staircase top rails. This Interclamp can be used where the top rail must be joined at the fitting. Where such a joint is not required, type 129 can often be used as an alternative. Often used in conjunction with type 130.

	a mm	b mm	c mm	d mm	e mm	Dia	Wt kg
B34		118					0.79
C42		147					1.21
D48		165					1.47

128 - Corner (Top Rail)

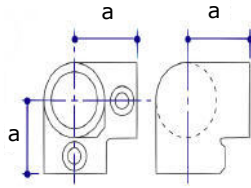

90° corner joint, often used where top rail meets corner upright on level sites. Often paired with type 116.

	a mm	b mm	c mm	d mm	e mm	Dia mm	Wt kg
A27	41						0.40
B34	48						0.53
C42	60						0.90
D48	68						1.08
E60	84						1.65

129 - Adjustable Short Tee

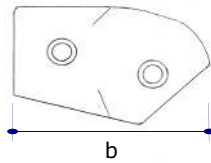

Adjustable from 30° to 60°, often used on staircase top rails and braces. The through tube (sloping in photo) cannot be joined within the fitting.

	a mm	b mm	c mm	d mm	e mm	Dia mm	Wt kg
A27		109					0.41
B34		109					0.57
C42		132					0.70
D48		146					0.86

130 - Adjustable Cross (Middle Rail)

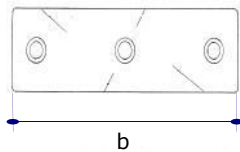

Adjustable from 30° to 45°, this Interclamp fitting is often used where middle rails on staircases meet intermediate uprights. The through tube (vertical in photo) cannot be joined within the fitting.

	a mm	b mm	c mm	d mm	e mm	Dia mm	Wt kg
B34		147					0.63
C42		181					0.86
D48		217					1.34

131 - Wall Flange

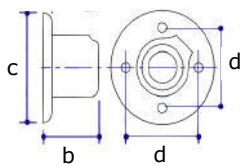

Positional fixing flange which is often used where rails meet walls on level sites. **Warning:** This Interclamp fitting is not recommended as a baseplate to support handrailing, guardrailing, parapets, balustrades or other structures. Please use type 132 as an alternative.

	a mm	b mm	c mm	d mm	e mm	Dia mm	Wt kg
A27		42	83	59		6.5	0.36
B34		48	89	65		6.5	0.49
C42		51	102	76		6.5	0.67
D48		59	114	88.5		6.5	0.87
E60		64	128	97		6.5	1.10

132 - Railing Base Flange

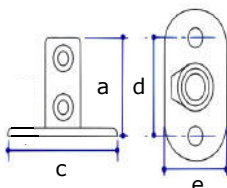

Base flange, usually used for uprights on level sites. Fixing holes suit a wide range of common mechanical and chemical masonry anchors which we should be pleased to quote for on request. Type 132-D48 is designed to meet the dimensional requirements for parapets as defined by BS7818:1995 (Pedestrian Retraint Systems in Metal).

Warning: To achieve optimum load characteristics, this fitting should be fitted so that the fixing holes are in line with the applied load.

	a mm	b mm	c mm	d mm	e mm	Dia mm	Wt kg
A27	76		114	76	60	10.5	0.46
B34	89		127	89	65	14.5	0.72
C42	102		139	101	76	14.5	0.94
D48	90		153	114	90	14.5	1.25
E60	127		165	127	102	17.5	1.80

133 - Plastic Stop End



Grey plastic stop end. Only suitable for tubes with similar dimensions to BS EN 10255 (formerly BS 1387) medium weight. Type 333 is an alternative in metal.

	a mm	b mm	c mm	d mm	e mm	Dia mm	Wt kg
A27							0.01
B34							0.01
C42							0.01
D48							0.02
E60							0.02

134 - Ground Socket

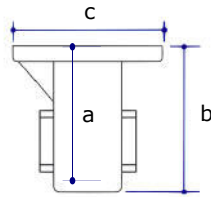

A setscrew allows the upright to be removed when required, the fitting remaining cast in place.

	a mm	b mm	c mm	d mm	e mm	Dia mm	Wt kg
B34	113	122	127				1.86
C42	125.5	135	139				2.66
D48	124.5	135	139				2.50

135 - Clamp-on Tee (1 Bolt)

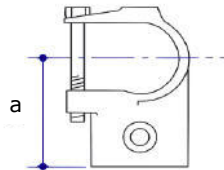

90° bolt-on joint, often used to make additions or alterations to existing structures where a type 101 or similar cannot be fitted. Type 136 is a similar clamp-on fitting offering a more flush finish. The through tube (horizontal in photo) cannot be joined within the fitting.

	a mm	b mm	c mm	d mm	e mm	Dia mm	Wt kg
A27	51						0.31
B34	52.5						0.40
C42	67						0.69
D48	76.5						0.66
E60	91						0.76

136 - Clamp-on Tee (2 Bolt)

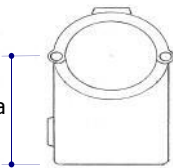

90° bolt-on joint, often used to make additions or alterations to existing structures where a type 101 or similar cannot be fitted. Type 135 is a similar clamp-on fitting. The through tube (horizontal in photo) cannot be joined within the fitting.

	a mm	b mm	c mm	d mm	e mm	Dia mm	Wt kg
C42	60						0.76
D48	69						0.62

137 - Clamp-on Crossover 90°

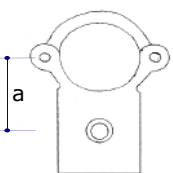

90° bolt-on joint, often used to make additions or alterations to existing structures where a type 161 cannot be fitted. The tubes cannot be joined within the fitting.

	a mm	b mm	c mm	d mm	e mm	Dia mm	Wt kg
D48	55						0.85

138 - Gate Eye

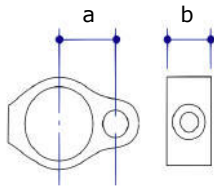

Often used with type 140 to form gate hinges. The tube cannot be joined within the fitting.

	a mm	b mm	c mm	d mm	e mm	Dia mm	Wt kg
A27	30	25.5				14	0.17
B34	33	25.5				14	0.20
C42	38	25				14	0.21
D48	41	25				14	0.26

140 - Gate Hinge Pin

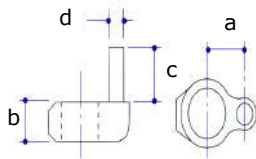

Often used with type 138 to form gate hinges. The tube cannot be joined within the fitting.

	a mm	b mm	c mm	d mm	e mm	Dia mm	Wt kg
A27	30	25.5	38	12			0.25
B34	33	25.5	38	12			0.24
C42	38	25	38	12			0.27
D48	41	25	38	12			0.34

143 - Handrail Wall Bracket

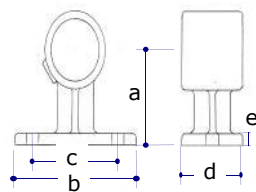

Often used to attach to walls, as a positional wall fixing for structures, or to attach kick-plates to uprights. The tube cannot be joined within the fitting.

	a mm	b mm	c mm	d mm	e mm	Dia mm	Wt kg
A27	54	77	57	44	7	8	0.34
B34	57	80	62	44	7	8	0.38
C42	62	102	82.5	45	7	8	0.49
D48	70	107	82.5	50	7	8	0.57

144 - Side Support (Vertical Base)

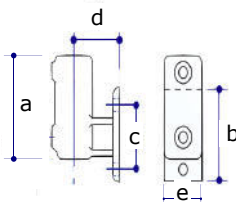

A palm-type fitting, often used to attach guardrail uprights to walls, staircases and ramps. In standard form, the tube cannot pass through the bottom of the fitting, although the fitting may be modified to accommodate this at extra cost. N.B. Access to one of the fixing holes is limited and may restrict the length and type of fixing that may be used. Dependent on load requirements, type 145 may sometimes be used as an alternative.

	a mm	b mm	c mm	d mm	e mm	Dia mm	Wt kg
B34	103	95	67	57	45	14.5	0.81
C42	112	110	72	63.5	54	14	1.12
D48	120	120	89	73	63	14	1.44

145 - Side Support (Horizontal Base)

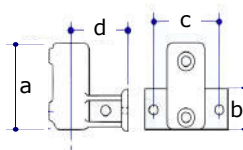

A palm-type fitting, often used to attach guardrail uprights to walls, staircases and ramps. In standard form, the tube cannot pass through the bottom of the fitting, although the fitting may be modified to accommodate this at extra cost. Dependent on load requirements, type 144 may sometimes be used as an alternative.

	a mm	b mm	c mm	d mm	e mm	Dia mm	Wt kg
B34	102	45	67	57		14.5	0.84
C42	111	53	73	64		14.5	1.08
D48	119	68	89	73		14.5	1.48

146 - Side Palm

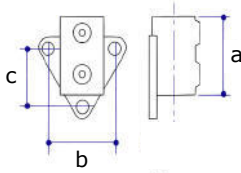

A palm-type fitting, often used to attach guardrail uprights to walls, staircases and ramps. In standard form, the tube cannot pass through the bottom of the fitting, although the fitting may be modified to accommodate this at extra cost (with loss of use of bottom bolt hole).

	a mm	b mm	c mm	d mm	e mm	Dia mm	Wt kg
B34	76	68	63			10	0.58
C42	83	81	71			10	0.77
D48	89	86	79			10	0.91

147 - Internal Swivel Tee

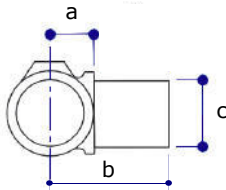

A versatile fitting, often used on slopes and staircases where the angle either varies or is unknown, and/or where there is a requirement for rails to be offset from uprights. Most commonly used with types 101 and 125 to mount sloping rails on to vertical uprights. The tube cannot be joined within the fitting.

	a mm	b mm	c mm	d mm	e mm	Dia mm	Wt kg
B34	22	60	34				0.32
C42	26	62.5	42				0.51
D48	30	72.5	48				0.60

148 - Swivel Short Tee

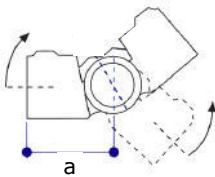

A versatile fitting, usually used in pairs. Although the photo shows two fittings, this item is sold and priced individually. The through tube (vertical in photo) cannot be joined within the fitting.

	a mm	b mm	c mm	d mm	e mm	Dia mm	Wt kg
A27	53						0.24
B34	59						0.29
C42	73						0.45
D48	93						0.63
E60	110						0.96

149 - External Sleeve Joint

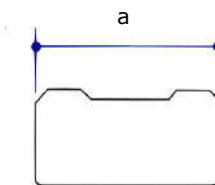

A straight fitting for joining tubes of the same size. Dependent on load requirements, type 150 may sometimes be used as an alternative, particularly where a more flush joint is required (N.B. Type 150 cannot be used for tensile loads).

	a mm	b mm	c mm	d mm	e mm	Dia mm	Wt kg
A27	76						0.30
B34	90						0.40
C42	100						0.55
D48	100						0.64
E60	120						0.99

150 - Internal Expanding Joint

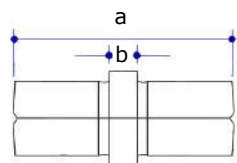

A straight fitting for joining tubes of the same size. This fitting can only be used for 3.25mm wall thickness tube (1", 1 1/4" & 1 1/2" BS EN 10255, formerly BS 1387, medium weight) and must not be used as a load bearing joint, particularly for tensile loads. Type 149, which has superior load characteristics, may sometimes be used as an alternative.

	a mm	b mm	c mm	d mm	e mm	Dia mm	Wt kg
B34	78	20					0.25
C42	78	20					0.38
D48	78	20					0.49

152 - Slope Base Flange 0° to 11°

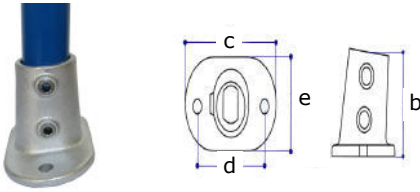

Base flange for sloping sites, adjustable from 0° to 11°, usually used for guardrail and wheelchair ramp uprights. Fixing holes suit a wide range of common mechanical and chemical masonry anchors which we should be pleased to quote for on request.

Warning: To achieve optimum load characteristics, this fitting should be fitted so that the fixing holes are in line with the applied load.

	a mm	b mm	c mm	d mm	e mm	Dia mm	Wt kg
B34		90	127	89	80	14.5	0.86
C42		98	140	101	90	14.5	1.08
D48		99	153	113	96	14.5	1.34

153 - Slope Short Tee 0° to 11°

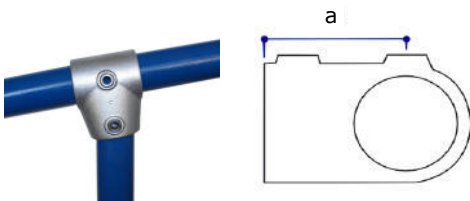

Butt joint for sloping sites, adjustable from 0° to 11°, often used to join intermediate uprights to top rails and middle rails to end uprights. This Interclamp cannot be used where through tube (sloping in photo) has to be joined within the fitting. Type 155 may often be used as an alternative.

Please also see our Interclamp Assist range of flush fittings to help compliance with the Disability Discrimination Act (DDA) and the Building Regulations Part M:2004.

	a mm	b mm	c mm	d mm	e mm	Dia mm	Wt kg
B34	46						0.37
C42	59						0.60
D48	68						0.76

154 - Slope Elbow 0° to 11°

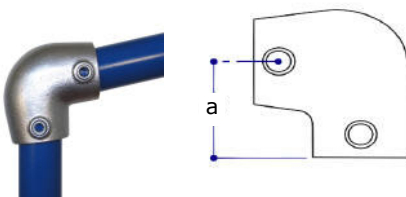

Angle joint adjustable for slopes from 0° to 11°, often used where top rail meets end upright on sloping sites.

Please also see our Interclamp Assist range of flush fittings to help compliance with the Disability Discrimination Act (DDA) and the Building Regulations Part M:2004.

	a mm	b mm	c mm	d mm	e mm	Dia mm	Wt kg
B34	46						0.40
C42	60						0.62
D48	68						0.97

155 - Slope Long Tee 0° to 11°

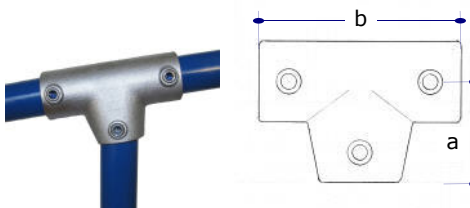

Adjustable for slopes from 0° to 11°, often used to join intermediate uprights to top rails and middle rails to end uprights. This Interclamp can be used where through tube (sloping in photo) has to be joined within the fitting. Type 155 may often be used as an alternative.

Please also see our Interclamp Assist range of flush fittings to help compliance with the Disability Discrimination Act (DDA) and the Building Regulations Part M:2004.

	a mm	b mm	c mm	d mm	e mm	Dia mm	Wt kg
B34	46	104					0.53
C42	60	145					1.00
D48	68	168					1.28

156 - Slope Cross (Middle Rail) 0° to 11°

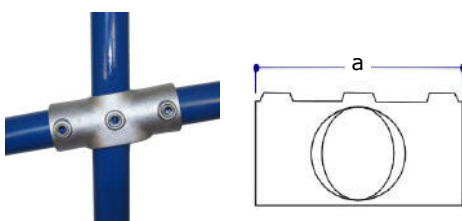

Adjustable for slopes from 0° to 11°, often used between middle rail and uprights on sloping sites and often paired with type 153 or 155. The through tube (vertical in photo) cannot be joined within the fitting.

	a mm	b mm	c mm	d mm	e mm	Dia mm	Wt kg
B34	112						0.48
C42	140						0.73
D48	158						0.92

158 - Centre Cross

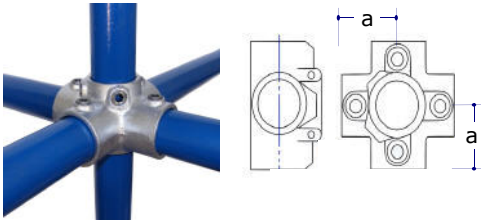

Designed to form a 90° joint between an upright which passes through the fitting and four other tubes. Usually used in the middle of larger structures such as self-contained play areas. The through tube (vertical in photo) cannot be joined within the fitting.

	a mm	b mm	c mm	d mm	e mm	Dia mm	Wt kg
A27	41						0.57
B34	46						0.62
C42	60						0.98
D48	68						1.24
E60	84						1.98

160 - Clamp-on Crossover

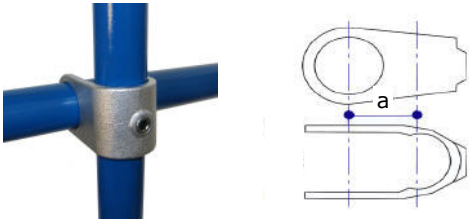

Designed to form a 90° joint between two tubes. Often used to add to existing structures. Type 137 can often be used as a clamp-on alternative, or type 161 can often be used as an alternative on new structures.

	a mm	b mm	c mm	d mm	e mm	Dia mm	Wt kg
A27	28						0.23
B34	34						0.33
C42	43.5						0.51
D48	49.5						0.57
E60	61						0.86

161 - Crossover

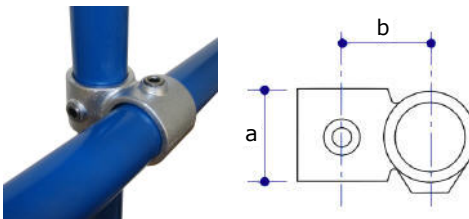

Designed to form a 90° crossover joint between two tubes, this fitting can reduce the need for cutting on horizontal rails. To add to existing structures, types 137 and 160 can often be used as alternatives.

	a mm	b mm	c mm	d mm	e mm	Dia mm	Wt kg
A27	31.5	38					0.36
B34	38.5	41					0.31
C42	46	49.5					0.47
D48	51	55					0.59
E60	61	67					0.88

161 - Reducing Crossover

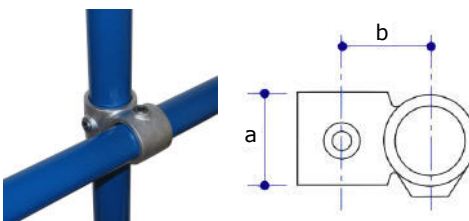

Designed to form a 90° crossover joint between two tubes of different sizes.

	a mm	b mm	c mm	d mm	e mm	Dia mm	Wt kg
C42/B34	45						0.41
D48/B34	48						0.45
D48/C42	51						0.52
E60/D48	60						0.73

165 - Combined Tee & Crossover

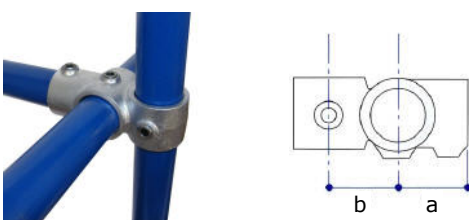

Often used in racking and similar structures, the fitting allows both uprights and front and rear horizontal rails to be continuous. It is usually preferable for the upright to be on the outside of the structure (as per the photo) for maximum stability. The through tubes cannot be joined within the fitting.

	a mm	b mm	c mm	d mm	e mm	Dia mm	Wt kg
B34	46	40					0.47
C42	60	49					0.72
D48	68	55					0.87
E60	84	68					1.32

166 - Adjustable Knuckle

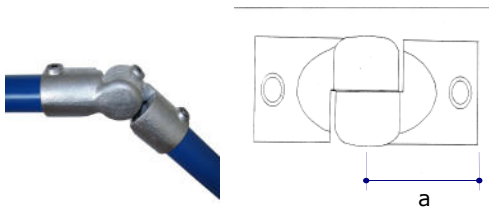

A versatile fitting, often used where a horizontal rail is joined to a sloping section. Once the desired angle is obtained, the knuckle is secured with a standard set-screw.

	a mm	b mm	c mm	d mm	e mm	Dia mm	Wt kg
B34	78						0.89
C42	88						1.26
D48	93						1.50
E60	110						2.35

167 - Double Swivel Combination

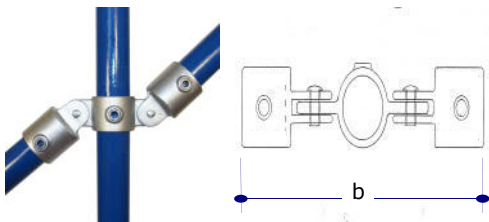

A versatile swivel fitting, useful for awkward applications where angles cannot be accommodated by adjustable angle fittings. The assembly is riveted together, although items can be supplied separately as 167M and 2 x 173F. The through tube (vertical in photo) cannot be joined within the fitting.

Warning: To provide sufficient stability, whole structures must not be made from swivel fittings alone.

	a mm	b mm	c mm	d mm	e mm	Dia mm	Wt kg
A27		202					0.86
B34		208					1.08
C42		228					1.33
D48		259					1.64
E60		300					2.33

167M - Double Swivel Male Part

Double lugged fitting. The tube cannot be joined within the fitting.

Warning: To provide sufficient stability, whole structures must not be made from swivel fittings alone.

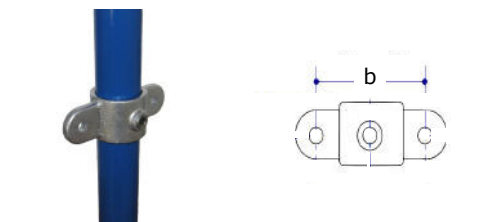

	a mm	b mm	c mm	d mm	e mm	Dia mm	Wt kg
A27		80					0.20
B34		84					0.27
C42		95					0.35
D48		105					0.49
E60		124					0.64

168 - 90° Corner Double Swivel Combination

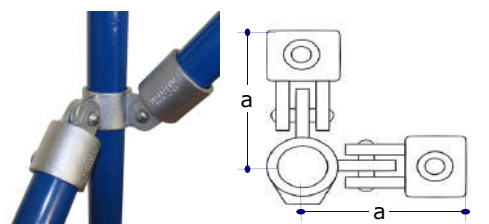

A versatile swivel fitting, useful for awkward applications where angles cannot be accommodated by adjustable angle fittings. The through tube (vertical in photo) cannot be joined within the fitting. The assembly is riveted together, although items can be supplied separately as 168M and 2 x 173F.

Warning: To provide sufficient stability, whole structures must not be made from swivel fittings alone.

	a mm	b mm	c mm	d mm	e mm	Dia mm	Wt kg
A27	101						0.85
B34	104.5						0.96
C42	117						1.50
D48	130						1.61
E60	149						2.30

168M - 90° Double Swivel Male Part

90° Double lugged fitting. The tube cannot be joined within the fitting.

Warning: To provide sufficient stability, whole structures must not be made from swivel fittings alone.

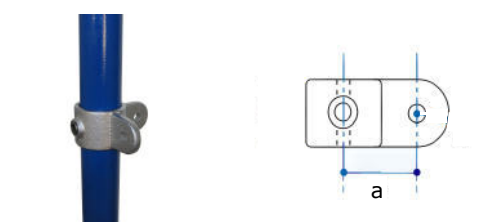

	a mm	b mm	c mm	d mm	e mm	Dia mm	Wt kg
A27	40						0.29
B34	43.5						0.26
C42	48						0.43
D48	53						0.36
E60	62						0.61

169 - Swivel Wall Fixing

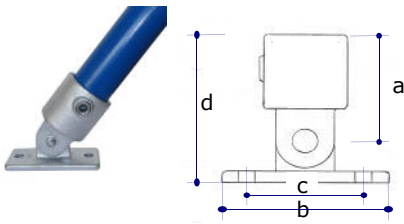

A versatile swivel fitting, useful for fixing angled tubes to walls etc. Fixing holes suit a wide range of common mechanical and chemical masonry anchors which we should be pleased to quote for on request. The assembly is riveted together, although items can be supplied separately as 169M and 173F.

Warning: To provide sufficient stability, whole structures must not be made from swivel fittings alone.

	a mm	b mm	c mm	d mm	e mm	Dia mm	Wt kg
A27	61	112	85	93		11	0.59
B34	61	112	85	93		11	0.72
C42	69	112	85	98		11	0.83
D48	77	112	85	109		11	0.96
E60	89	112	85	121		11	1.22

169M - Swivel Wall Fixing Male Part

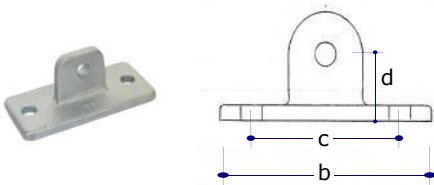

A versatile swivel fitting, useful for fixing angled tubes to walls etc. Fixing holes suit a wide range of common mechanical and chemical masonry anchors which we should be pleased to quote for on request. N.B. This fitting is available in one size only to suit all sizes of type 173F.

Warning: To provide sufficient stability, whole structures must not be made from swivel fittings alone.

	a mm	b mm	c mm	d mm	e mm	Dia mm	Wt kg
169M		112	85	32		10.5	0.35

170 - Single Mesh Panel Clip

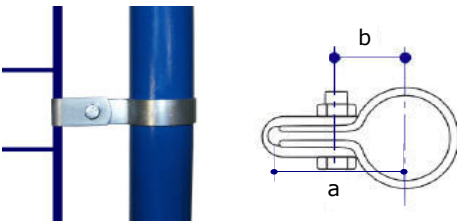

For attaching mesh panels to one side of tube. For double-sided clips, please refer to type 171. This fitting may also be used without the small return part to secure certain other types of sheet material to tubes eg. Board. The tube cannot be joined within the fitting.

N.B. This item is manufactured from steel, not malleable iron.

	a mm	b mm	c mm	d mm	e mm	Dia mm	Wt kg
A27	50-64	24-38					0.09
B34	54-64	28-38					0.07
C42	60-70	34-44					0.07
D48	62-72	34-44					0.08
E60	70-80	45-55					0.08

171 - Double Mesh Panel Clip

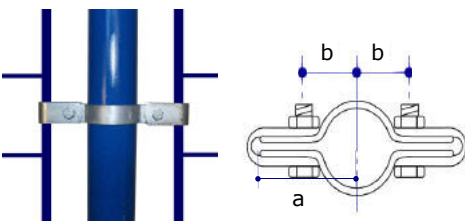

For attaching mesh panels to both sides of tube. For single-sided clips, please refer to type 170. This fitting may also be used without the small return part to secure certain other types of sheet material to tubes eg. Board. The tube cannot be joined within the fitting.

N.B. This item is manufactured from steel, not malleable iron.

	a mm	b mm	c mm	d mm	e mm	Dia mm	Wt kg
A27	50-64	24-38					0.11
B34	54-64	28-38					0.10
C42	60-70	34-44					0.11
D48	62-72	34-44					0.13
E60	70-80	45-55					0.12

173 - Single Swivel Combination

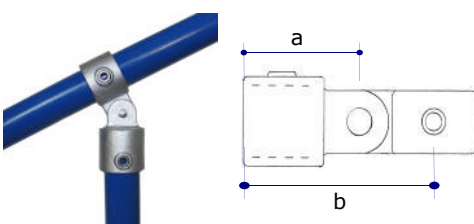

A versatile swivel fitting, useful for awkward applications where angles cannot be accommodated by adjustable angle fittings. The through tube (sloping in photo) cannot be joined within the fitting. The assembly is riveted together, although items can be supplied separately as 173M and 173F.

Warning: To provide sufficient stability, whole structures must not be made from swivel fittings alone.

	a mm	b mm	c mm	d mm	e mm	Dia mm	Wt kg
A27	61	106					0.43
B34	61	104.5					0.59
C42	69	117					0.78
D48	77	130					0.96
E60	89	152					1.35

173F - Single Swivel Combination Female Part



Versatile fitting with a multitude of uses. Can be supplied pre-assembled with other fittings to form types 167, 168, 169 and 173.

Warning: To provide sufficient stability, whole structures must not be made from swivel fittings alone.

	a mm	b mm	c mm	d mm	e mm	Dia mm	Wt kg
A27	61						0.26
B34	61						0.32
C42	69						0.46
D48	77						0.57
E60	89						0.85

173M - Single Swivel Combination Male Part

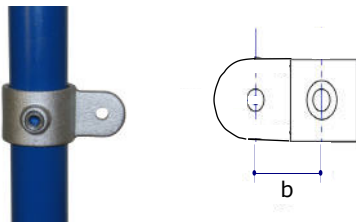

Single lugged fitting. Can be supplied pre-assembled to type 173F to form type 173. Dependent on load requirements, this fitting may sometimes be used to fix flat sheets to tubes. The tube cannot be joined within the fitting.

Warning: To provide sufficient stability, whole structures must not be made from swivel fittings alone.

	a mm	b mm	c mm	d mm	e mm	Dia mm	Wt kg
A27		40					0.16
B34		43.5					0.27
C42		48					0.30
D48		53					0.37
E60		60					0.51

174 - Swivel Tee

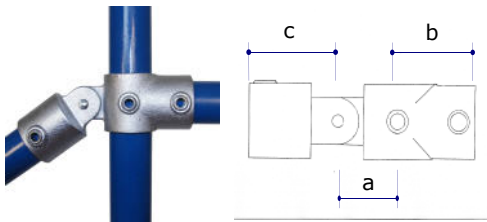

A versatile swivel fitting, often used for braces and where staircase middle rails join level sections. The through tube (vertical in photo) cannot be joined within the fitting. The assembly is riveted together, although items can be supplied separately as 174M and 173F.

Warning: To provide sufficient stability, whole structures must not be made from swivel fittings alone.

	a mm	b mm	c mm	d mm	e mm	Dia mm	Wt kg
D48	53	68	77				1.25

174M - Swivel Tee Male Part



Short tee with single lug. The through tube (vertical in photo) cannot be joined within the fitting.

Warning: To provide sufficient stability, whole structures must not be made from swivel fittings alone.

	a mm	b mm	c mm	d mm	e mm	Dia mm	Wt kg
D48	53	68					0.67

175 - Swivel Elbow

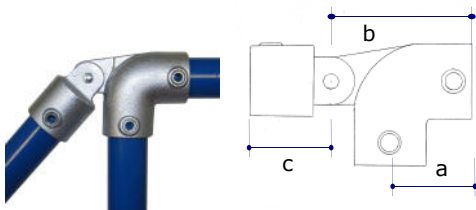

A versatile swivel fitting, often used for braces and where staircase top rails join level sections. The assembly is riveted together, although items can be supplied separately as 175M and 173F.

Warning: To provide sufficient stability, whole structures must not be made from swivel fittings alone.

	a mm	b mm	c mm	d mm	e mm	Dia mm	Wt kg
D48	68	117	77				1.47

175M - Swivel Elbow Male Part



90° Elbow with single lug.

Warning: To provide sufficient stability, whole structures must not be made from swivel fittings alone.

	a mm	b mm	c mm	d mm	e mm	Dia mm	Wt kg
D48	68	117					0.89

176 - Side Outlet Tee

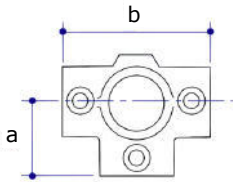

Often used in large tubular structures with the upright passing through the fitting. The through tube (vertical in photo) cannot be joined within the fitting.

	a mm	b mm	c mm	d mm	e mm	Dia mm	Wt kg
A27	41	82					0.27
B34	46	92					0.48
C42	60	120					1.05
D48	68	136					0.98
E60	84.5	169					2.23

179 - Locking Ring

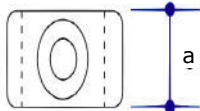

Often used with other fittings to increase slip load capacity or to support other fittings which are left to rotate freely on tube to form swivels, hinges etc. The tube cannot be joined within the fitting.

	a mm	b mm	c mm	d mm	e mm	Dia mm	Wt kg
A27	25						0.09
B34	25						0.12
C42	25						0.20
D48	25						0.19

182 - Hook

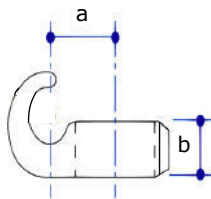

Usually used where chains need to be easily removed for access. The tube cannot be joined within the fitting.

	a mm	b mm	c mm	d mm	e mm	Dia mm	Wt kg
B34	34	25					0.19
C42	39	25					0.22
D48	41	25					0.23

185 - Eaves Fitting 27 1/2°

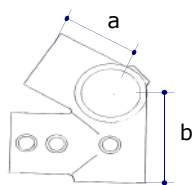

Usually used to form roof structures in conjunction with type 191, with an angle of 27 1/2°. The horizontal eaves tube running longitudinally with the roof may be joined within the fitting (there are two setscrews acting on this tube, which are obscured in the photo).

	a mm	b mm	c mm	d mm	e mm	Dia mm	Wt kg
D48	68	90					1.60

191 - Ridge Fitting 27 1/2°

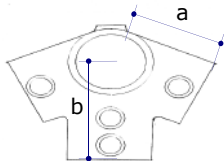

Usually used to form roof structures in conjunction with type 185, with an angle of 27 1/2°. The ridge tube running longitudinally with the roof may be joined within the fitting (there are two setscrews acting on this tube, which are obscured in the photo).

	a mm	b mm	c mm	d mm	e mm	Dia mm	Wt kg
D48	68	90					1.39

192 - Weather Cowl

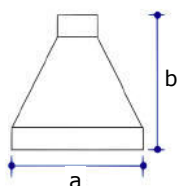

This shield fits over type 132 and is sealed with silicone sealant (available separately at extra cost). This is often used on flat roofs to add additional protection against water ingress. Please contact us for installation instructions.

	a mm	b mm	c mm	d mm	e mm	Dia mm	Wt kg
B34	143						0.23
C42	143						0.25
D48							0.33

198 - Double-Lugged Bracket

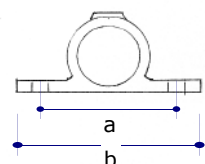

Often used for mounting boards practically flush with tubes. Fixing holes suit a wide range of common mechanical and chemical masonry anchors which we should be pleased to quote for on request. The tube cannot be joined within the fitting.

	a mm	b mm	c mm	d mm	e mm	Dia mm	Wt kg
B34	86	120					0.30
C42	95	130					0.40
D48	104	140					0.46
E60	124	160					

199 - Single-Lugged Bracket

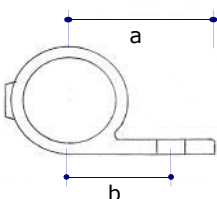

Often used for mounting boards practically flush with tubes. Fixing holes suit a wide range of common mechanical and chemical masonry anchors which we should be pleased to quote for on request. The tube cannot be joined within the fitting.

	a mm	b mm	c mm	d mm	e mm	Dia mm	Wt kg
B34	60	43					0.23
C42	66	48					0.29
D48	70	52					0.46

300 - Setscrew



High-quality setscrews, a vital component in the high structural integrity of the fittings. Please specify "Standard Length" or "Long" when ordering, as two lengths are used across the range (in two diameters) - please ask for further details.

N.B. All fittings are supplied with setscrews fitted as standard.

	Thread BSP	Hex AF	c mm	d mm	e mm	Dia mm	Wt kg
A27 & B34	1/4"	1/4"					0.02
C42, D48 & E60	3/8"	5/16"					0.02

301 - Hexagon Keys



High-quality imperial size hexagon keys.

	Hex AF	b mm	c mm	d mm	e mm	Dia mm	Wt kg
A27 & B34	1/4"						0.06
C42, D48 & E60	5/16"						0.06

302 - Flexi Ratchet & Bit Set



Ratchet with flexible head to reach awkward positions, supplied with both 1/4" and 5/16" AF bits.

	a mm	b mm	c mm	d mm	e mm	Dia mm	Wt kg
302							0.17

305 - Plastic Setscrew Covers



Push-fit grey plastic covers for an aesthetically pleasing finish to the setscrews.

	a mm	b mm	c mm	d mm	e mm	Dia mm	Wt kg
A27 & B34							0.00
C42, D48 & E60							0.00

310 - Floor Grating Clip



To secure floor grating.

N.B. This item is manufactured from steel, not malleable iron.

	a mm	b mm	c mm	d mm	e mm	Dia mm	Wt kg
A27							0.15

333 - Aluminium Stop End



Aluminium alloy stop end. Only suitable for tubes with identical dimensions to BS EN 10255 (formerly BS 1387) medium weight. Type 133 is an alternative in plastic.

	a mm	b mm	c mm	d mm	e mm	Dia mm	Wt kg
A27							0.01
B34							0.02
C42							0.04
D48							0.05

390 - Silver Zinc Galvanising Spray



Aerosol paint which does not require a separate primer. Can be used as an excellent touch-up paint on damaged surfaces or for the protection of cut tube ends eg. cut tubes fitted to the Assist range.

	Vol ml	b mm	c mm	d mm	e mm	Dia mm	Wt kg
390	400						0.41

392 - Pedestrian Barrier Panel



Designed to integrate fully with the Interclamp system, to provide rapid construction of pedestrian control structures. Top and bottom rails are 1 1/2" nominal bore (48.3mm od) tube with 12mm solid vertical bars. To improve visibility for drivers through the barriers, the bars are staggered. The barriers meet the infill requirements of Sections 2.4.1 and 2.4.2 of BS 7818:1995 (Pedestrian Restraint Systems in Metal). Custom sizes are also available on request.

	a mm	b mm	c mm	d mm	e mm	Dia mm	Wt kg
D48							14.00

394 - Mesh Panel

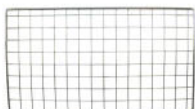

Manufactured to order on request to suit customer's requirements, Mesh Panels are supplied welded to an 8mm rod frame and are available in common mesh sizes eg. 50 x 50mm, 25 x 25mm and 50 x 25mm. Bent corner panels are also available



Interclamp Assist Range

The Interclamp Assist range has been specially designed to help compliance with the Disability Discrimination Act (DDA) and the Building Regulations Part M:2004. Unlike many brands, the Assist range is assembled very quickly and easily by hexagon key,

with no riveting, drilling of tube, welding, threading or specialist tools required. Furthermore, no other special fittings are required, which enables full integration with both new Interclamp systems and the refurbishment or upgrading of existing tubular structures to help meet the newer access specifications.

In order to meet the requirements of the above standards, the range forms flush joints with size C42 tube. Tube (and fittings where necessary) may be coated in BS or RAL colours to help meet "not cold to the touch" and contrasting colour requirements. Steps and disabled access slopes may easily be accommodated, facilitating compliance with public access standards.

Please note, tubes must be 42.4mm od x 3.2mm wall thickness eg. 1 1/4" medium weight to BS EN 10255 (formerly 1387). All cut tube ends must be deburred and treated with Interclamp Silver Galvanising Spray or other suitable protection. Optional O-rings may be fitted to each end of the expanding Assist fittings to achieve the best finish. Patent applied for.

Assist Assemblies

The following illustrations show typical combinations of Interclamp Assist fittings. Type 133 may substitute type 333 if required. In some cases, size of type 101 may be modified to suit D48 size post. The assemblies illustrated may require more than one of each Assist fitting. Bolts and Nuts for type 750 are sold separately.

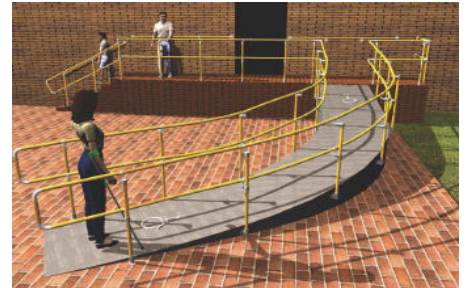

725-C42
+
731-C42



747-C42
+
101-C42
+
333-C42



747-C42
+
125-C42



725-C42
+
731-C42



750-C42
+
173F-C42



725-C42
+
101-C42/B34
+
333-C42

723 - Assist Rail Return

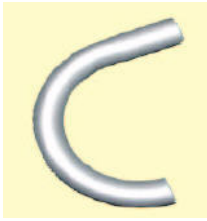

Designed to reduce the risk of clothing being caught on the end of handrails when fitted to 745, 747 or 750. This item is supplied with a type 133 plastic stop end fitted to one end.

N.B. Type 333 aluminium stop end will not fit this product.

	a mm	b mm	c mm	d mm	e mm	Dia mm	Wt kg
C42							1.50

725 - Assist Elbow

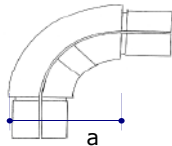

90° elbow to suit 1 1/4" medium weight tube to BS EN 10255 (formerly BS 1387), or alternatively to be used with type 731 to terminate handrail to a wall.

	a mm	b mm	c mm	d mm	e mm	Dia mm	Wt kg
C42	72						0.82

731 - Assist Wall Flange

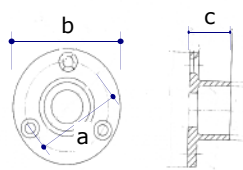

Used in conjunction with type 725 to terminate handrail neatly into wall.

N.B. This item is not suitable for direct connection to tube or fittings other than type 725. (Please refer to type 131 to join tube directly to a wall.)

	a mm	b mm	c mm	d mm	e mm	Dia mm	Wt kg
C42	63	82	32				0.28

745 - Assist Wall Bracket

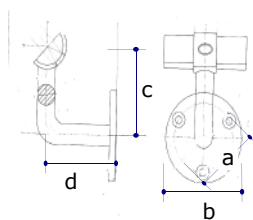

To attach the handrail to a wall at any angle.

	a mm	b mm	c mm	d mm	e mm	Dia mm	Wt kg
C42	63	82	80	76.5			1.00

747 - Assist Internal Swivel Bracket

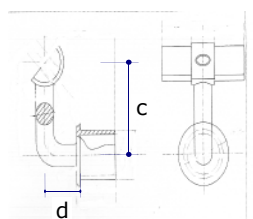

To attach handrail to an upright at any angle when used in conjunction with type 101 or 125 for a single rail or type 104 for a double rail.

	a mm	b mm	c mm	d mm	e mm	Dia mm	Wt kg
C42			80	38.5			0.87

750 - Assist Fitting with Male Lug

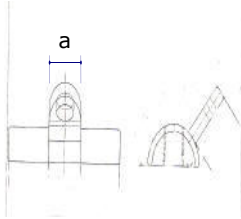

Designed to attach a freestanding handrail to an upright at any angle when used in conjunction with type 173F. Bolts and nuts are supplied separately at extra cost.

	a mm	b mm	c mm	d mm	e mm	Dia mm	Wt kg
C42	25.5						0.50

797 - Assist O-Ring (Optional)



An optional extra to be fitted to each end of the expanding Assist fittings, to attain the best finish.

	a mm	b mm	c mm	d mm	e mm	Dia mm	Wt kg
C42							0.001

Installation Guide

Base & Wall Fittings

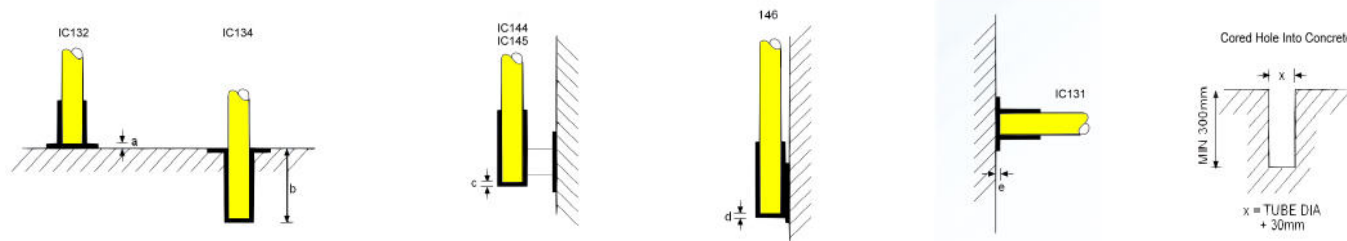

	a mm	b mm	c mm	d mm	e mm
A27	6				5
B34	8	10	8	8	5
C42	8	10	8	8	6
D48	8	11	9	8	6
E60	9				6

Subtract dimension a, c, d or e from tube length. Dimension b is to be added to the tube length. Dependent on the structure and design loads, concrete pockets to cast uprights into must be a minimum of 300 x 300 x 300mm.

Warning: Type 131 is for positional fixing only. It is not recommended as a baseplate to support handrailing, guardrailing, parapets, balustrades or other structures. Please use type 132 as an alternative.

Typical Inline Uprights on Level Ground

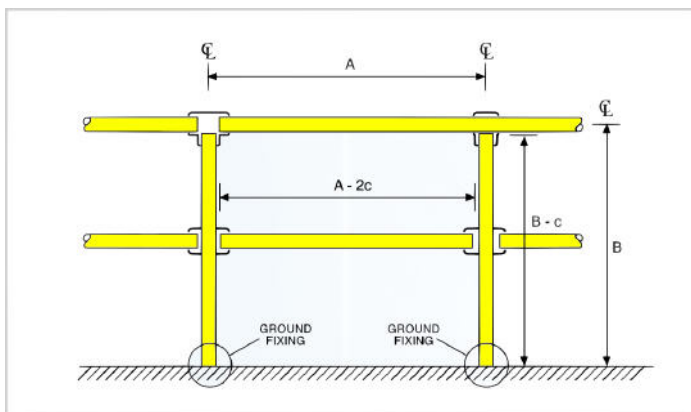

To calculate the tube length for uprights and rails for types 101, 104, 116, 117, 119, 125, 128, 135, 136, 158 & 176, please refer to the diagram (left).

A = Centre to centre distance of uprights

B = Distance from ground level to centre line of top rail

B - c = Upright tube length

A - 2c = Horizontal lower tube length

	c mm
A27	14
B34	17
C42	22
D48	25
E60	31

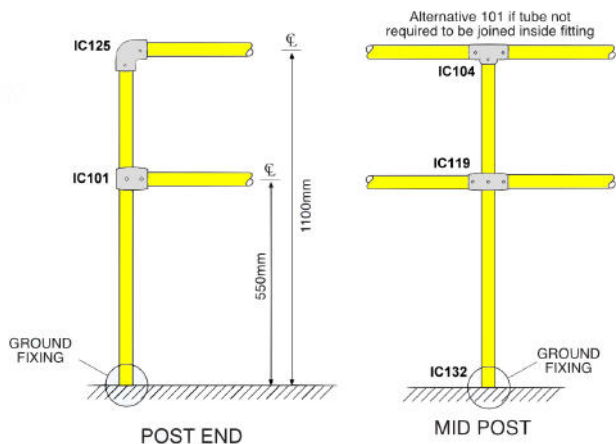

Typical Inline Uprights on a Slope of 1° to 11°

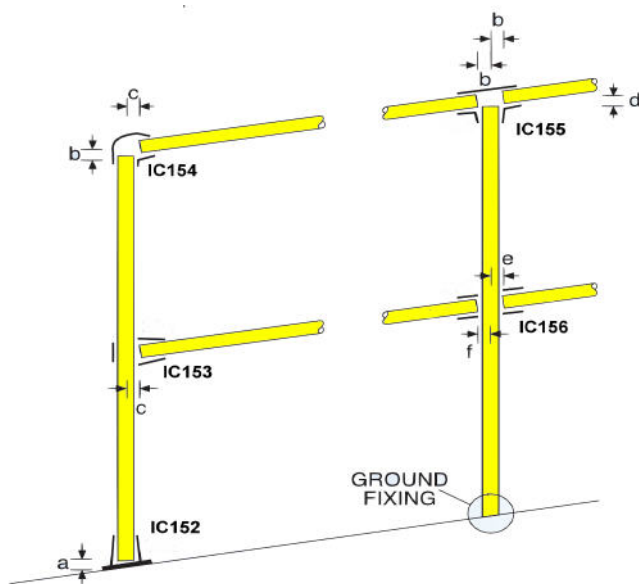

If a joint is not required in the top rail, type 153 should be used as an alternative to type 155.

Typical Inline Uprights for Adjustable Angles of 30° to 45°

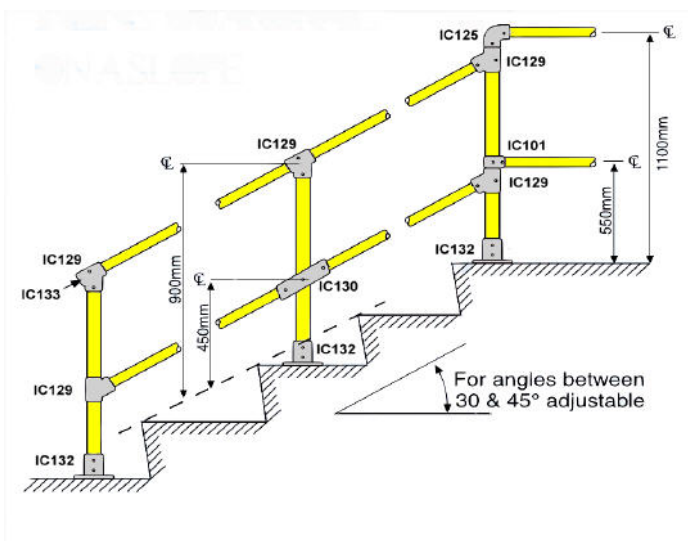

If the top rail needs to be joined at the upright, type 127 may be used instead of type 129 at this point.

Important Information

Illustrated in this publication are the main types of Interclamp designs available. Please note that we are continuously expanding and developing the range, so if the fitting or size you require is not shown, please contact us. Certain illustrations may show powder coated Interclamp fittings, tube and pedestrian barriers, available at extra cost. Photographs may be of foreign applications which do not necessarily conform to all market specifications.

Whilst every effort has been taken to ensure the information given in this publication is correct, the right is reserved to alter or amend this information as and when necessary. No part of this publication may be reproduced without the written permission of Grainger Tubolt Limited. We cannot be held responsible for any errors or omissions, nor any resultant loss or damage from improper use of the fittings. All dimensions and weights are subject to manufacturing tolerances and may be altered without prior notice.

PLEASE CHECK ANY CRITICAL DIMENSIONS WITH US PRIOR TO ANY DRILLING, TUBE CUTTING OR CASTING OF UPRIGHTS ETC.

Interclamps - only genuine when branded Interclamp

© 2008 Grainger Tubolt Limited. All rights reserved. Interclamp is a registered trademark.